

These instructions refer only to the installation of the roof flashing unit. Please refer to the guidance on [Planning the Layout](#) as described in the Sun Lite™ Tubular Rooflight fixing instructions.

Initial work in the roof void

1. From inside the loft space mark the centre point for the desired location of the tube on the underside of the roof construction.
2. In order to locate the position when on the roof, drill a small hole through the underside of the roof construction / underlay and insert a piece of dowel or a screw as a guide.
3. The remainder of the installation work for the roof mounting unit will need to be carried out on the roof. You may find it useful to take some reference measurements of the position of the marker to aid finding its location when on the roof.

External Installation Procedure

4. Locate the intended installation (if necessary by using the reference measurements as suggested in step 3 above). For existing roofs, remove the tiles in the area to expose the dowel or screw marker inserted earlier.
5. Position the roof flashing over the marker and check the position of the adjacent tiles. If necessary adjust the location so that the bottom contacts the top edge of the tile course below and the lead apron overlaps it. The tiles on either side of the unit may need to be cut, if so, the position of the unit can again be re-located to make the tile cutting easier. Check that the final location will not interfere with a rafter or other obstruction.
6. Measure the distance from the top edge of the roof flashing to the top edge of the first batten below. If the distance is greater than 75mm, fix a short length of support batten across the rafters aligned with the top edge of the roof flashing ([Figure 1](#)).
7. With the roof mounting in the correct location, gently insert the top tube until it makes contact with the battens. **DO NOT REMOVE THE PROTECTIVE FILM FROM INSIDE THE TUBE.** Carefully mark the inside line of the tube onto the face of the battens and the roof underlay.
8. Remove the roof flashing and starter tube and cut away the sections of the tiling battens that pass through the marked circle.
9. Slit the underlay diagonally from two sides inside the circle to form 4 triangular shaped flaps. The flaps can then be folded away to the sides and the ends nailed to the top surface of the adjacent battens. Pull the underlay up slightly to create a raised area around the tube entry ([Figure 2](#)).

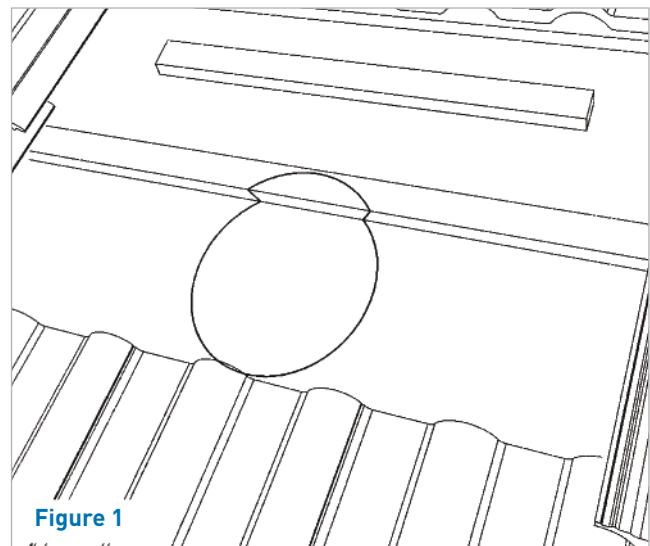

Figure 1

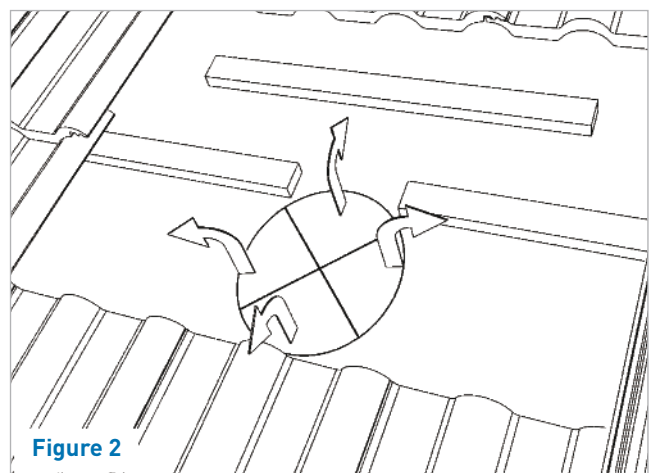
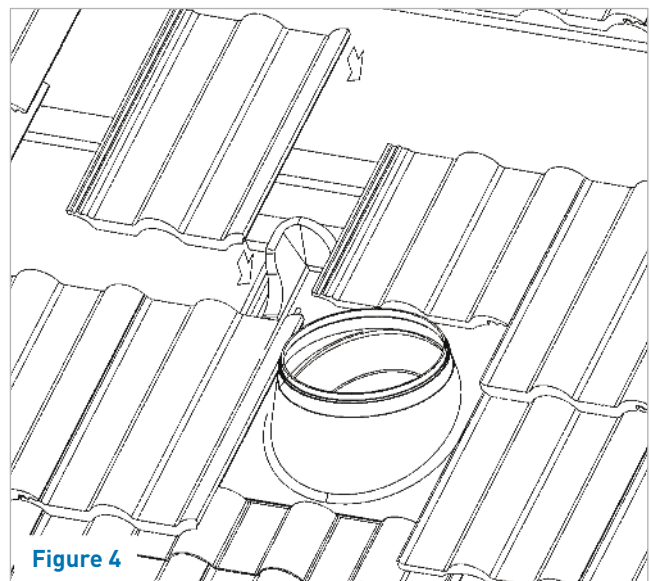
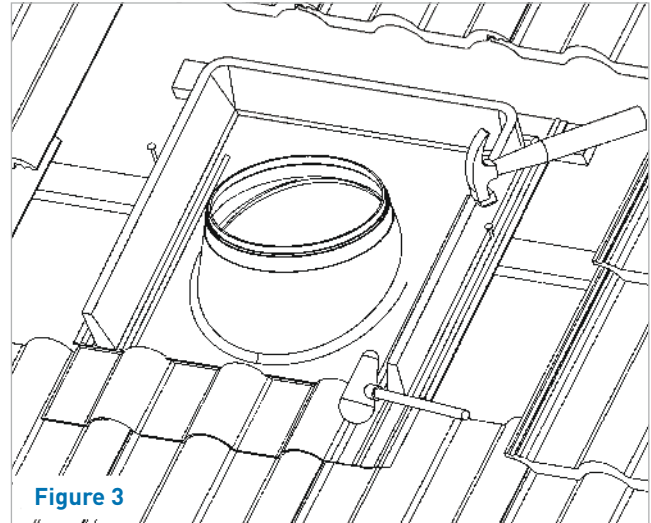

Figure 2

10. Replace the mounting unit in position ensuring that it is fully supported on the battens and that it is correctly aligned to enable the top tube to be fully inserted through the hole in the underlay. Fix into place by nailing through into the battens. For profiled tiles, dress the front lead apron into the profile of the tiles below to ensure a waterproof junction (Figure 3).

11. Replace the adjacent tiles so that they overlap the roof flashing base and compress the foam filler. If necessary cut the tiles so that they are a close fit around the projection of the roof flashing. If full tiles can be used, it may be necessary to remove the tile nibs to prevent 'kicking-up' (Figure 4). Fix adjacent tiles where necessary.

12. Now refer to the main fixing instruction to continue with the Sun Lite™ installation.



Our Guarantee is valid only when the Flashing Unit is fitted according to these instructions.

Keylite Roof Windows Ltd.,
Derryloran Ind. Est.,
Sandholes Road, Cookstown,
Co. Tyrone BT80 9LU

Tel: 028 8675 8921
Fax: 028 8675 8923

E-mail: info@keylite.co.uk
Website: www.keylite.co.uk

Keylite Roof Windows Ltd.,
Ryder Close, Cadley Hill Ind. Est.,
Swadlincote,
South Derbyshire DE11 9EU

Tel: 01283 200150
Fax: 01283 223352

E-mail: info@keyliteuk.com
Website: www.keylite.co.uk